

Aksonometrijsko projektovanje

Aksonometrija je način prostornog prikazivanja predmeta. Za razliku od perspektive, kod aksonometrije paralelne ivice na predmetu zadržavaju takav položaj i na crtežu.

Kod aksonometrije jedna ivica predmeta crta se vertikalno, tj. normalno na horizontalnu osu i uvek u pravoj veličini.

U zavisnosti od skraćanja ostale dve dimenzije (ivice) predmeta, razlikujemo:

- dimetričku aksonometriju,
- trimetričku aksonometriju,
- izometričku aksonometriju.



Dimetrička aksonometrija

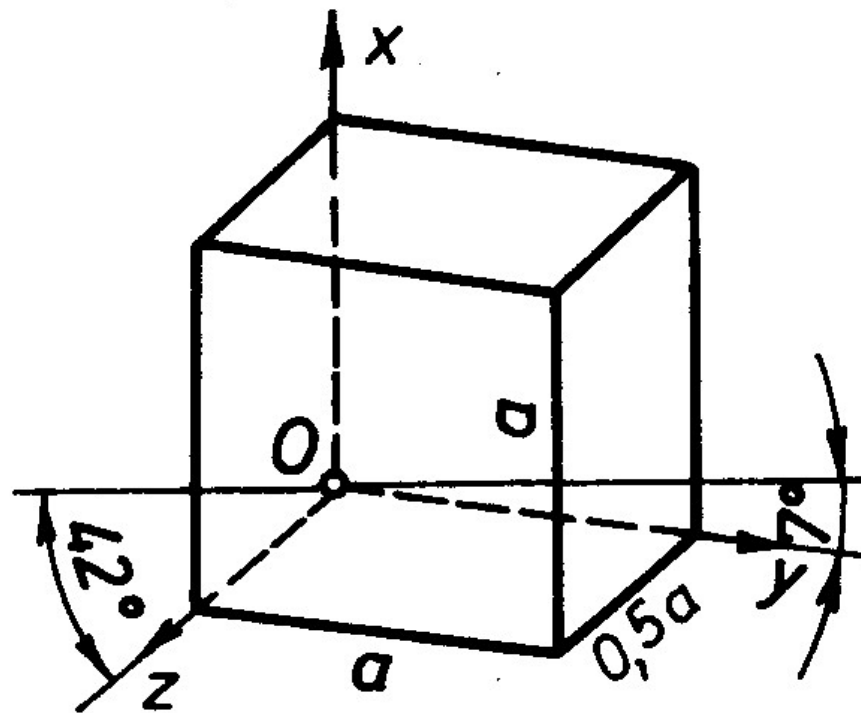

Trimetrička aksonometrija

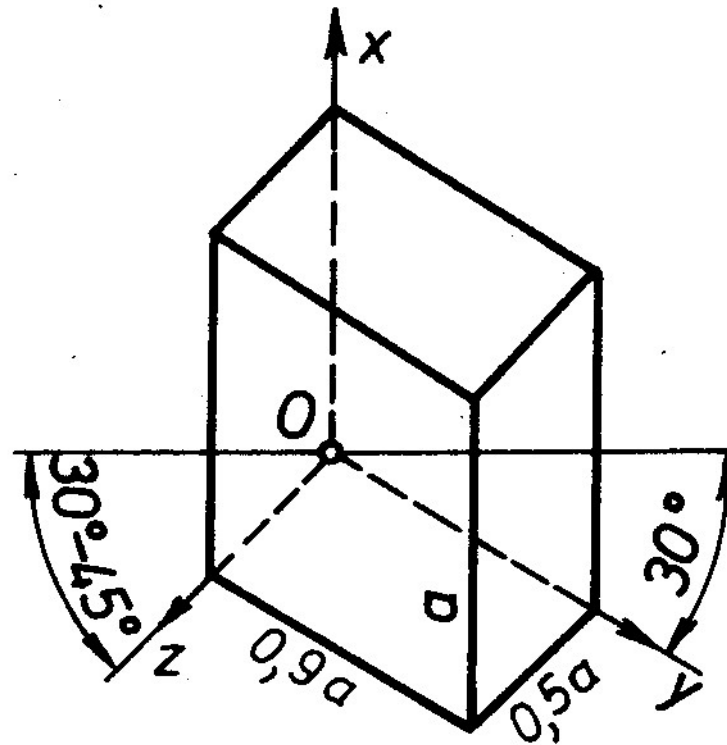

Izometrička aksonometrija

Od pomenutih vrsta aksonometrija u inženjerskoj grafici najčešće se koristi **izometrička** aksonometrija, kod koje se sve tri dimenzije (visina, širina i debljina) prikazuju neskraćeno. Ivice koje predstavljaju širinu i debljinu nagnute su prema horizontali pod uglom od 30° .

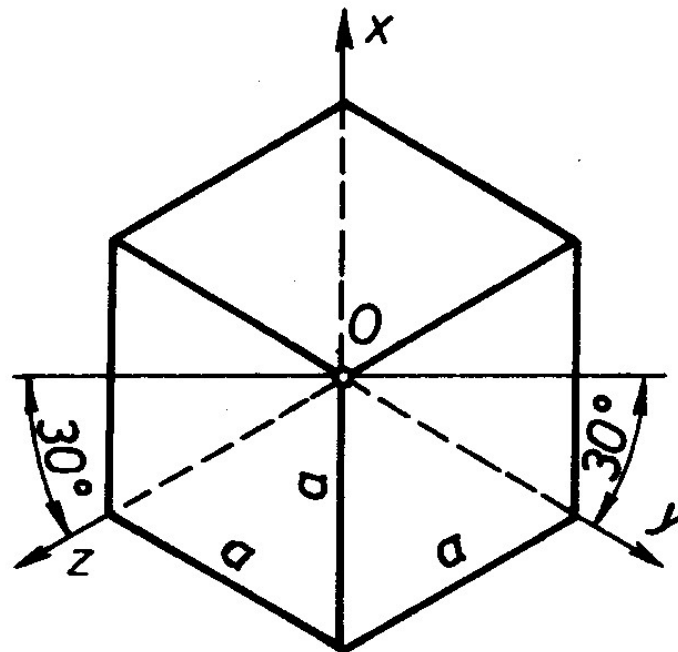

Kosa projekcija

Kosa projekcija je način prostornog prikazivanja koji se posle izometrije najčešće primenjuje. Kod kose projekcije se cela jedna površina (visina, širina) crta u pravoj veličini, dok se treća dimenzija crta skraćeno.

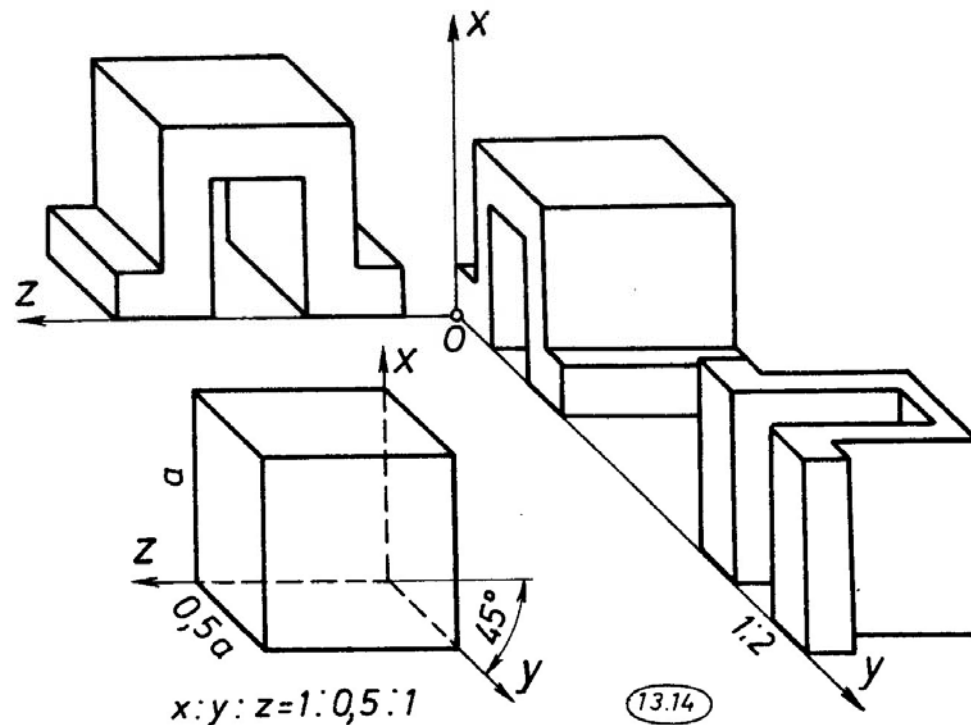

Obla tela u izometriji

Kružnica se u izometriji projektuje kao elipsa

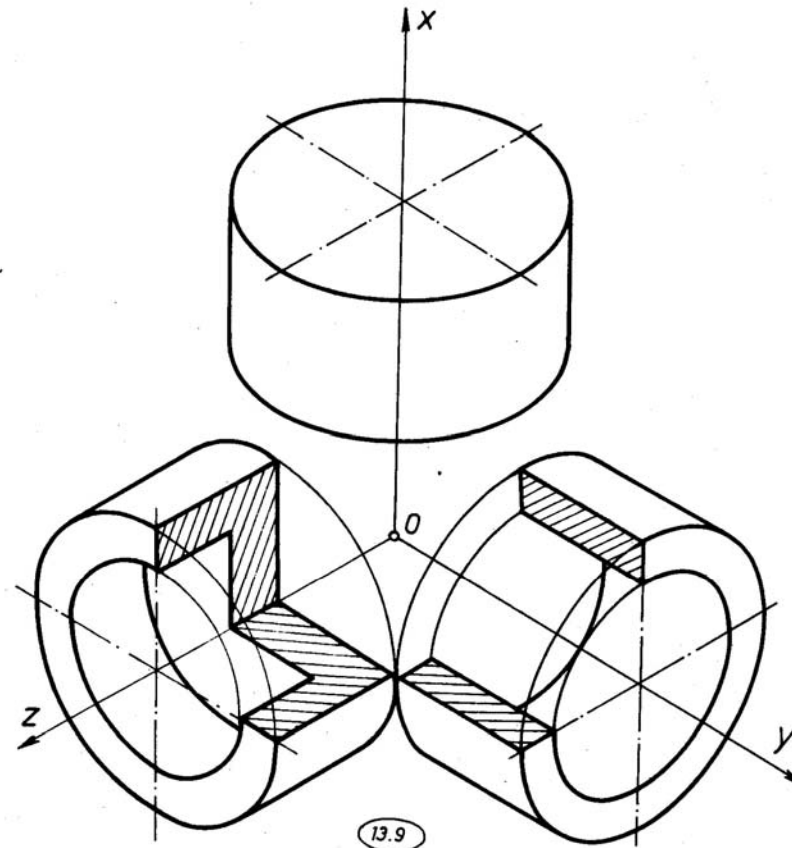

Kosa projekcija oblih tela

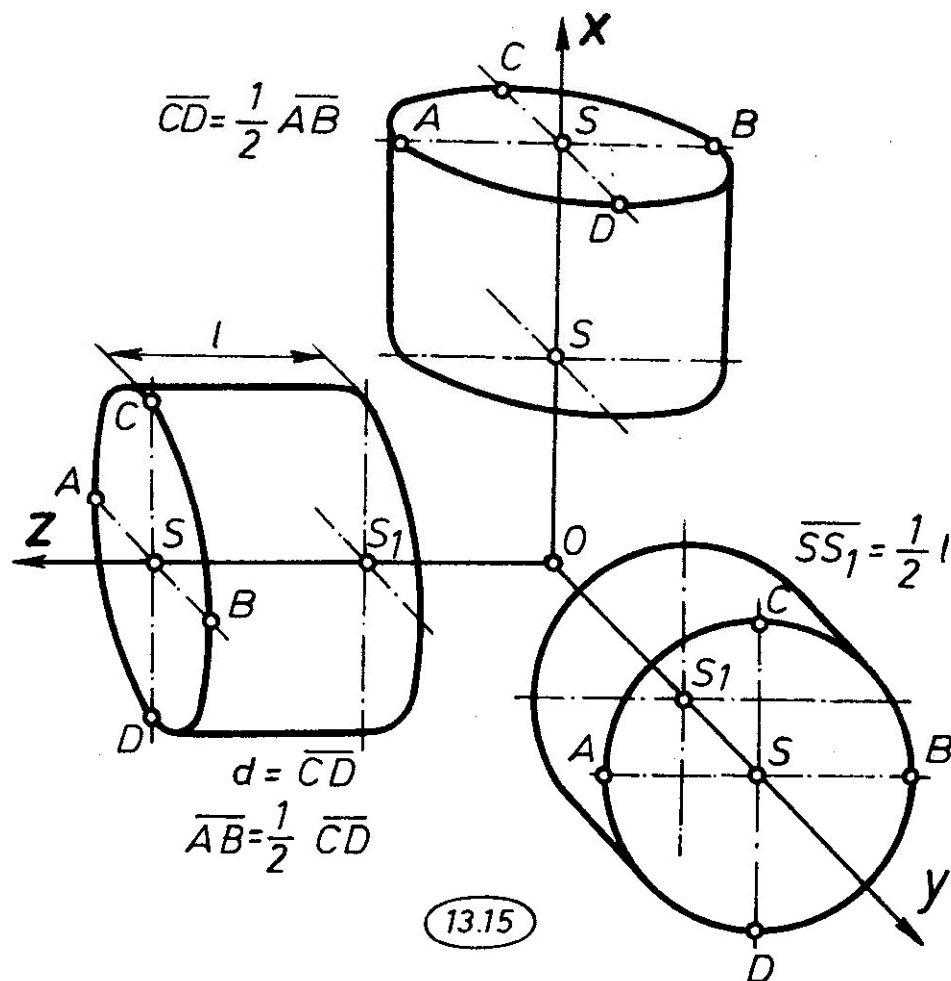

Aksonometrijsko projektovanje u SOLID WORKS-u

- U SW se uvek kreiraju 3D (aksonometrijski – “izometrijski”) modeli i 2D crteži.
- Oni su stalnoj vezi jer se sve izmene prenose iz jednog u drugi model i obratno.
- SW je zasnovan na parametarskom projektovanju. To znači da je deo potpuno dimenziono definisan i dimenzije se mogu u svakom trenutku promeniti.
- Parametarske relacije u SW uspostavljaju veze između elemenata mašinskog dela
- Izmenama relacija i parametara mašinskog dela lako se dobijaju cele familije sličnih delova pa se projektovanje ubrzava.



Aksonometrijsko projektovanje u SOLID WORKS-u

Mašinski deo se crta pomoću osnovnih oblika i operacija.
Osnovni oblici su:

- osnovno dodavanje (***Base-Extrude***),
- naknadno dodavanje (***Boss-Extrude***),
- oduzimanje (***Cut-Extrude***),
- ubacivanje rupa (***Hole***),
- dodavanje rebara (***Rib***),
- zaokretanje profila (***Revolve***),
- praćenje putanje (***Sweep***),
- spajanje različitih poprečnih preseka (***Loft***).



Aksonometrijsko projektovanje u SOLID WORKS-u

Mašinski deo se crta pomoću osnovnih oblika i operacija.

Osnovne operacije su:

- zaobljenje (*Fillet*),
- obaranje ivica (*Chamfer*)
- izdubljivanje (*Shell*).



Osnovno dodavanje (*Base-Extrude*)

Insert > Base > Extrude

Animacija:

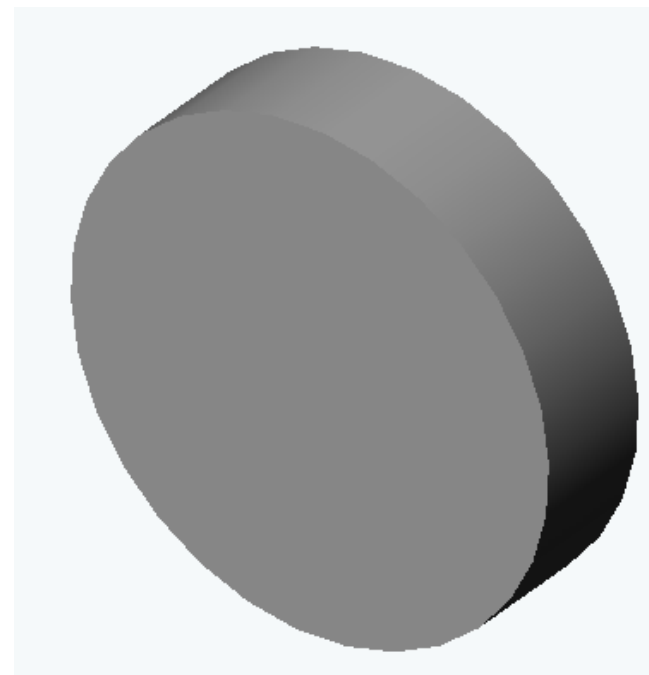
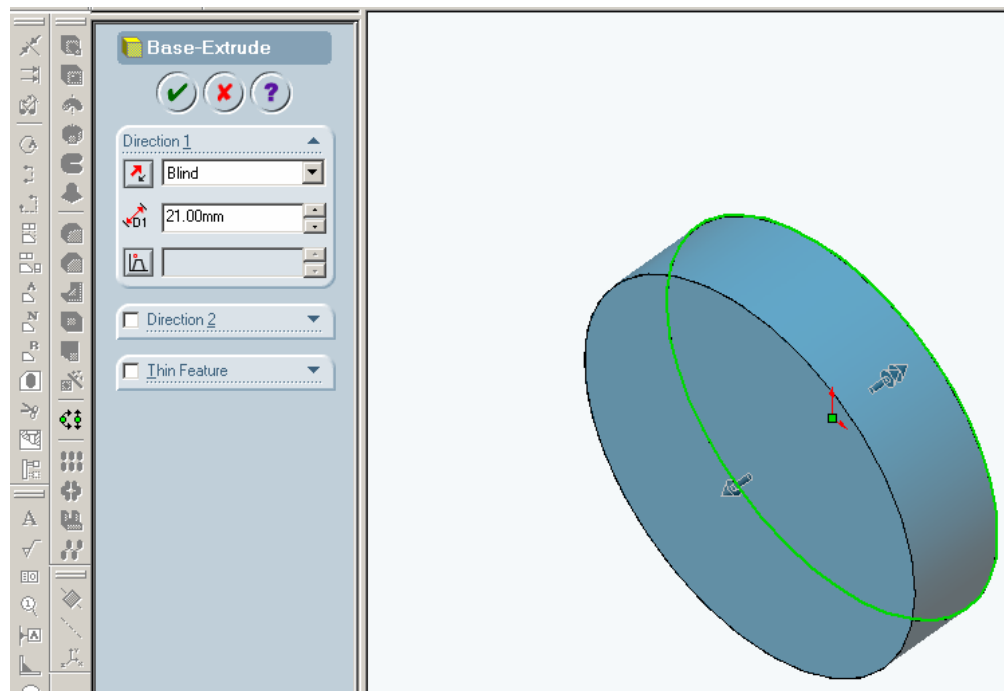

Naknadno dodavanje (Boss-Extrude)

Insert > Boss > Extrude

Animacija:

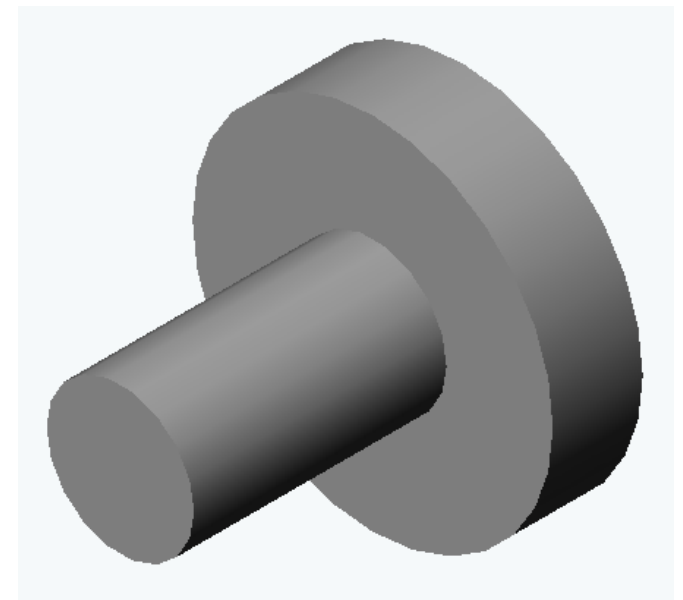
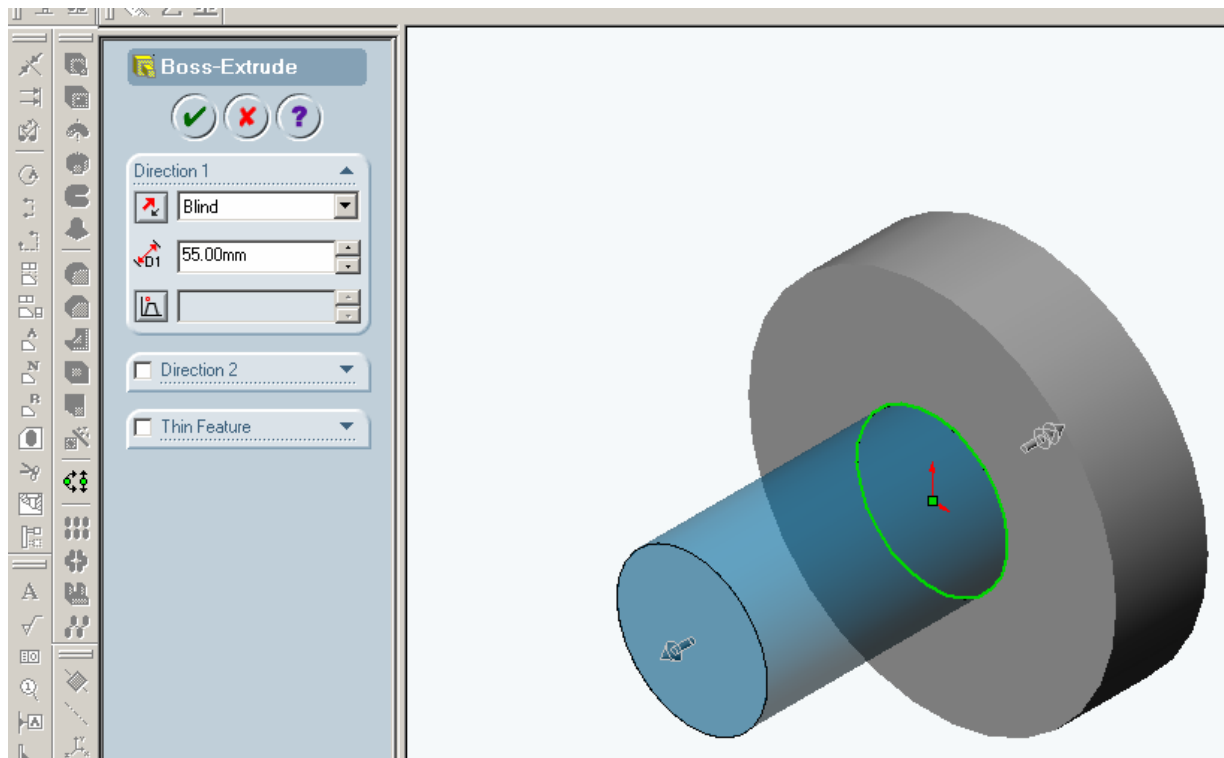

Oduzimanje (Cut-Extrude)

Insert > Cut > Extrude

Animacija:

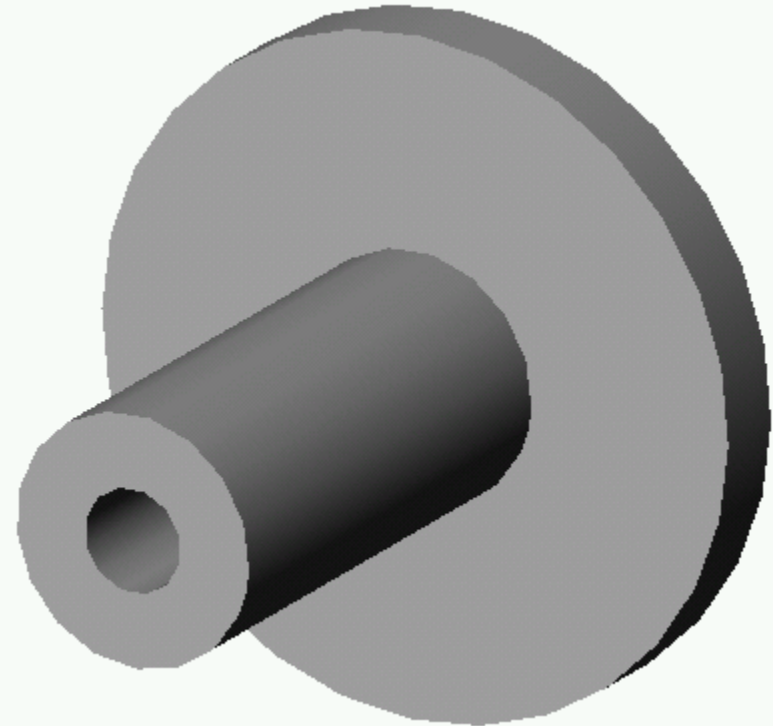
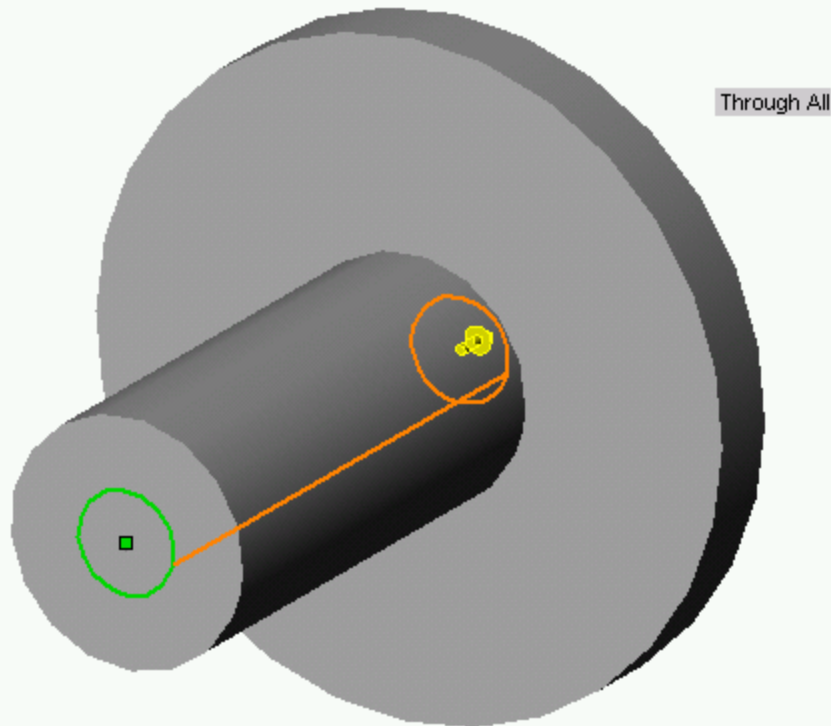

Ubacivanje rupa (Hole Wizard)

Insert > Features > Hole > Wizard

Animacija:

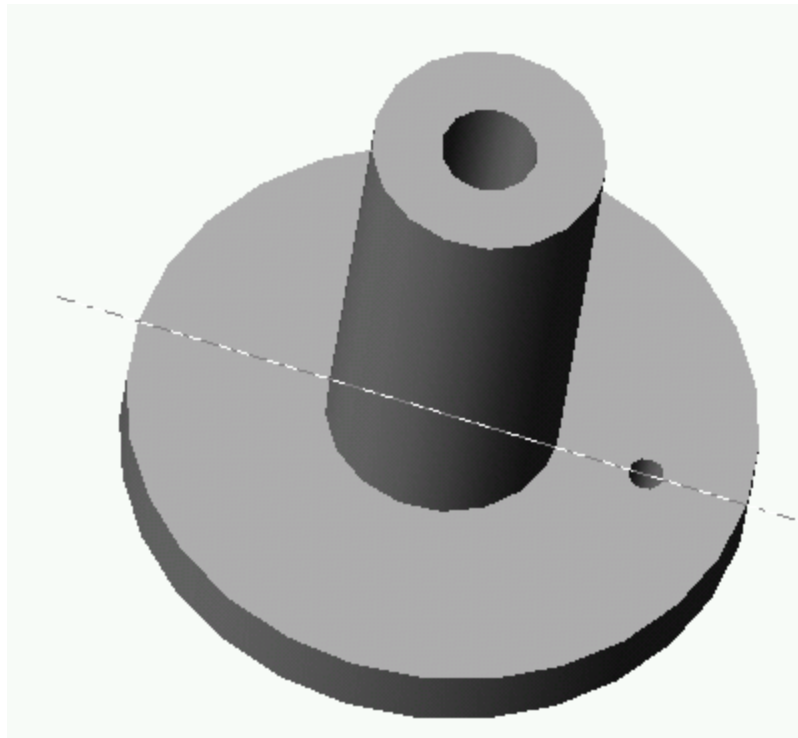

Dodavanje rebara (Rib)

Insert > Features > Rib

Animacija:

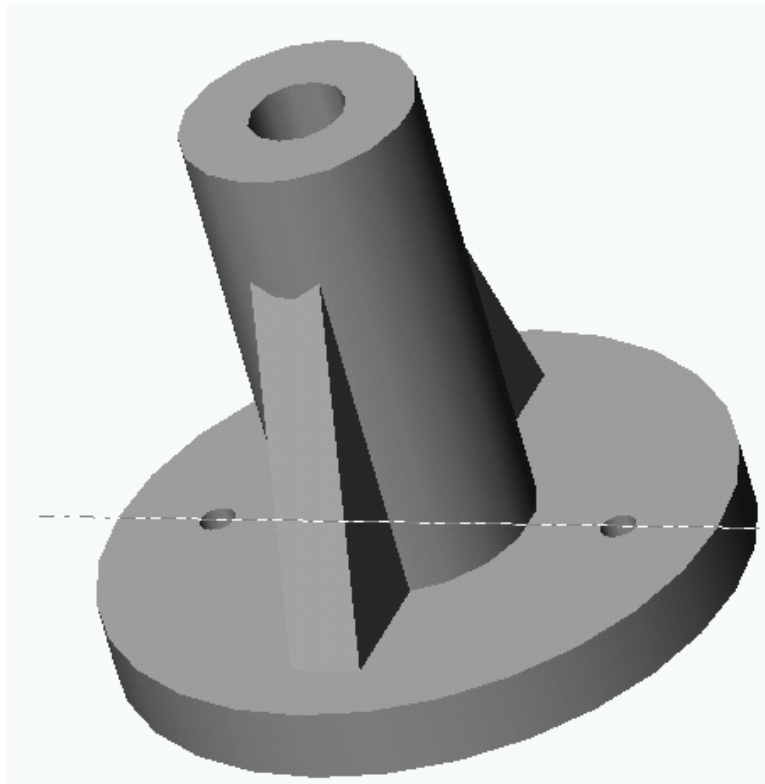

Obaranje ivica (Chamfer)

Insert > Features > Chamfer

Animacija:

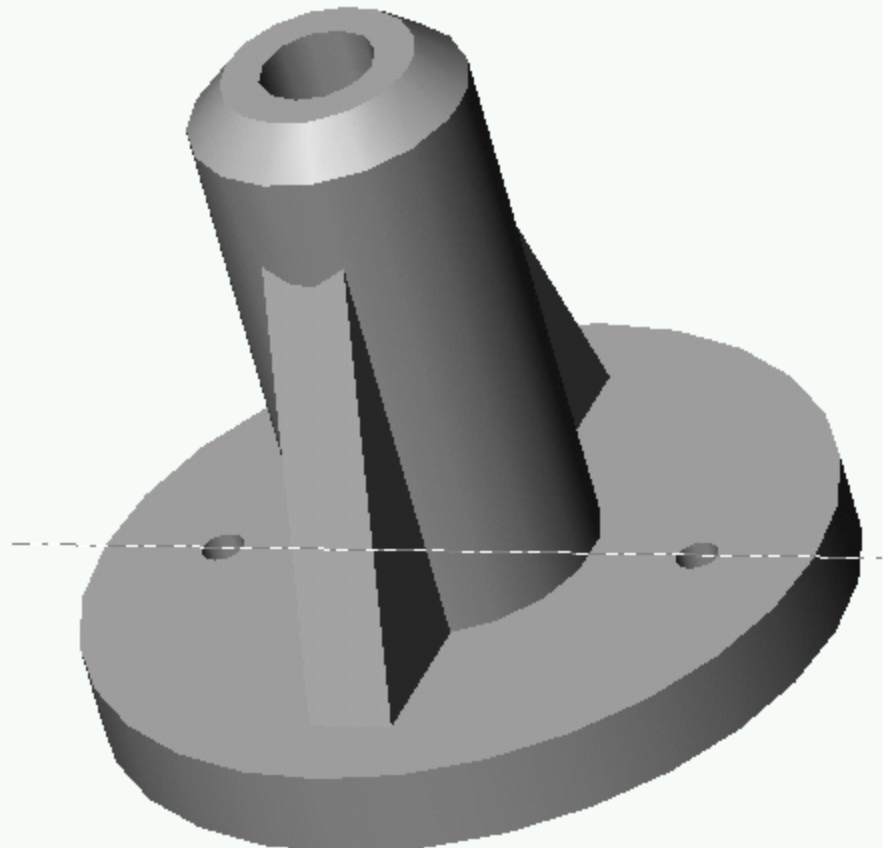

Zaobljenja (*Fillet*)

Insert > Features > Fillet / Round

Animacija:

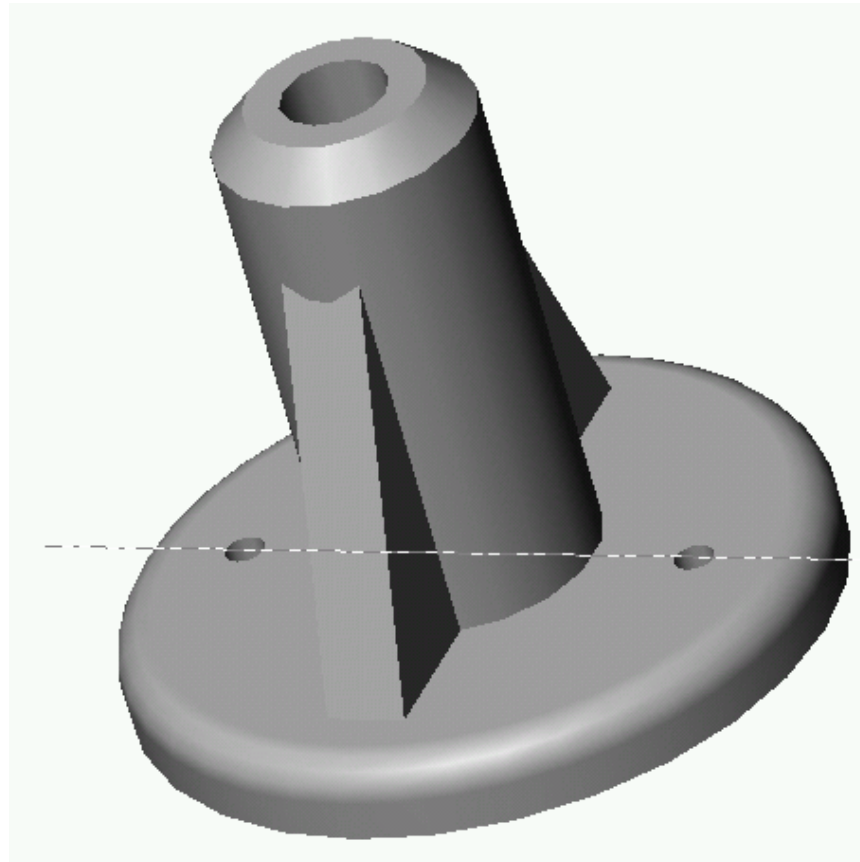

Izdubljanje (Shell)

Insert > Features > Shell

Animacija:

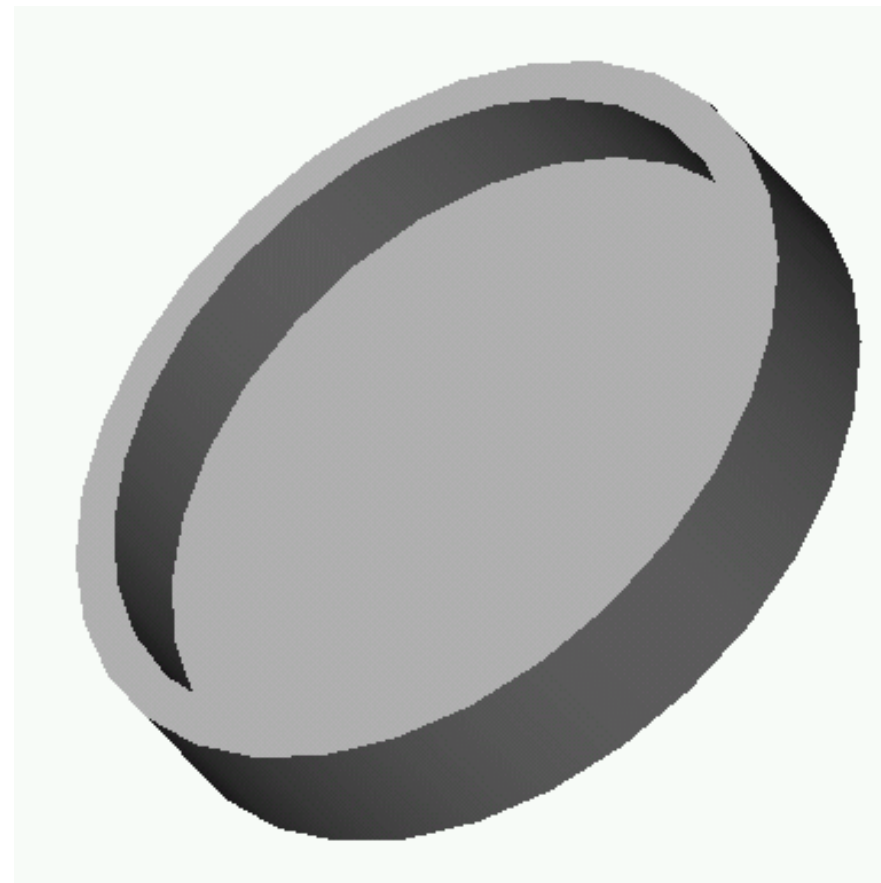

Zaokretanje profila (Revolve)

Insert > Base > Revolve

Animacija:

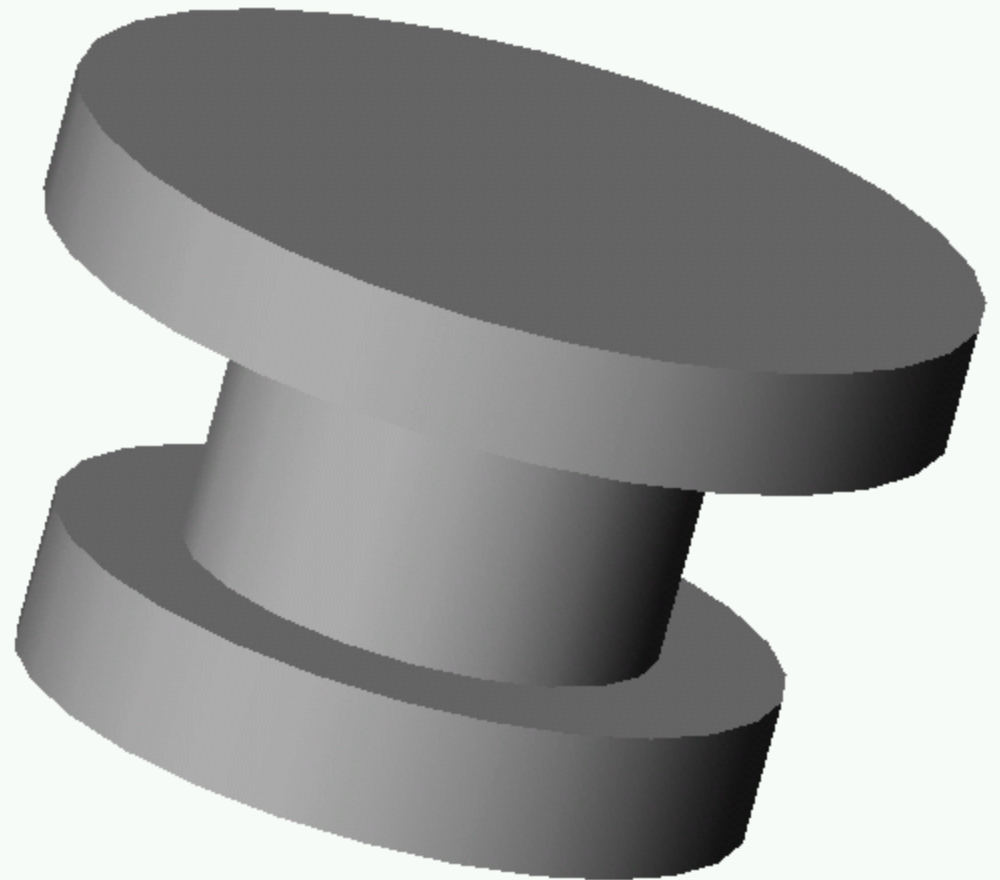
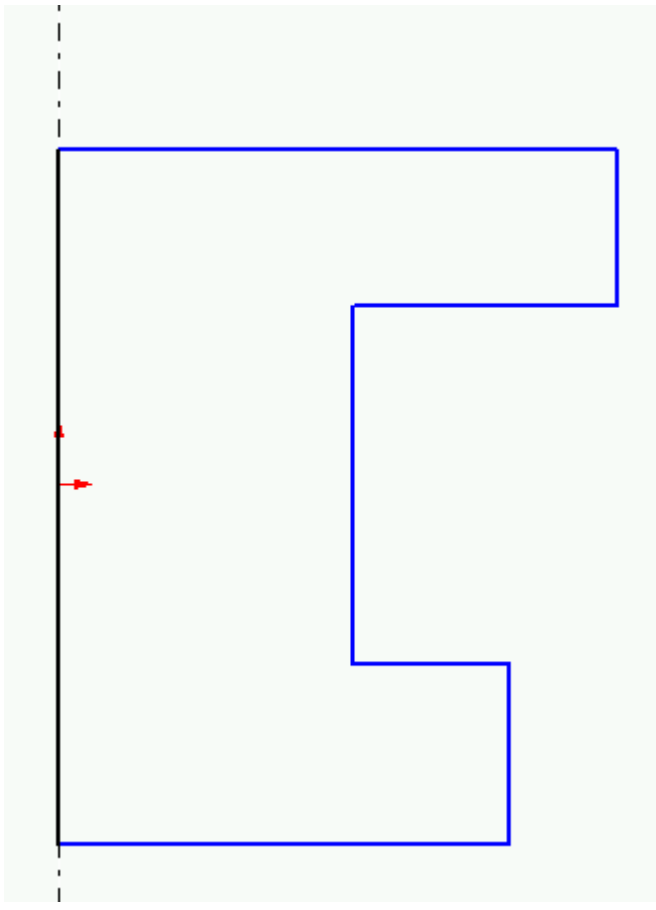

Praćenje putanje (Sweep)

Insert > Boss > Sweep

Animacija:

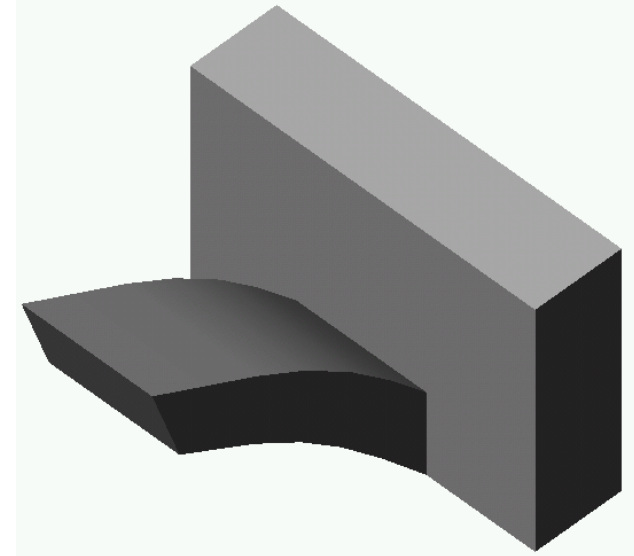
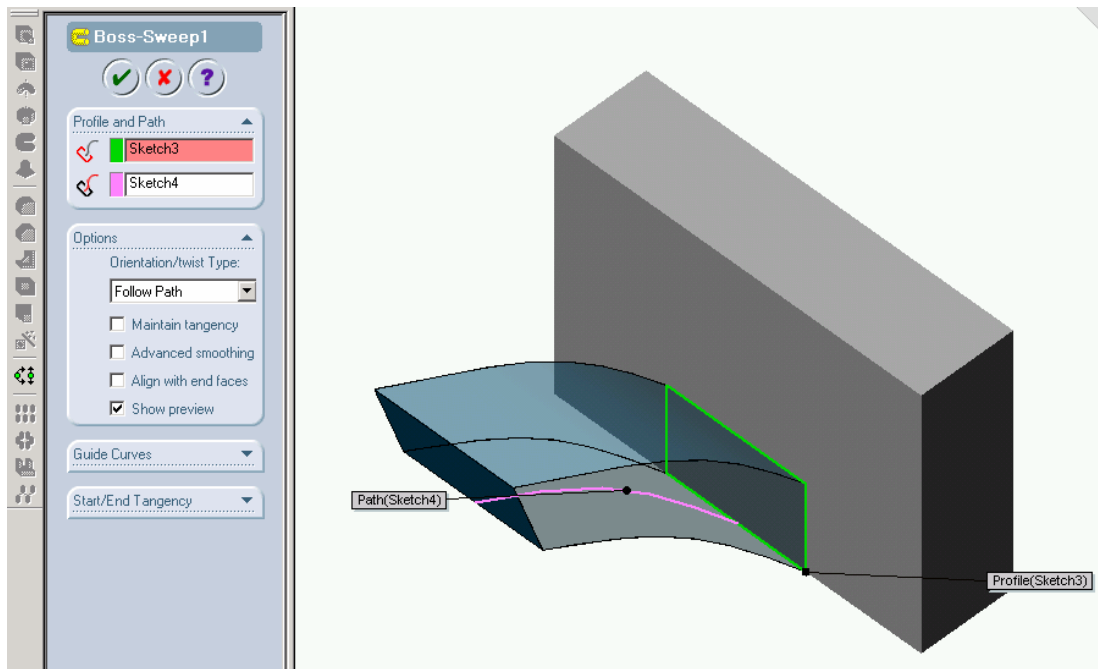

Spajanje različitih poprečnih preseka (Loft)

Insert > Boss > Loft

Animacija:

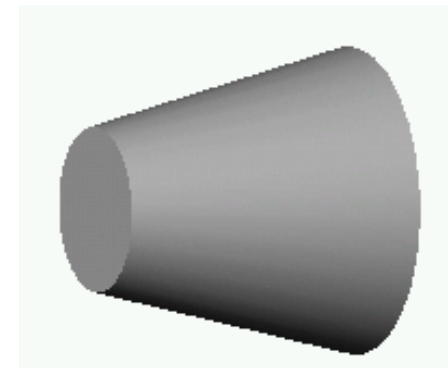
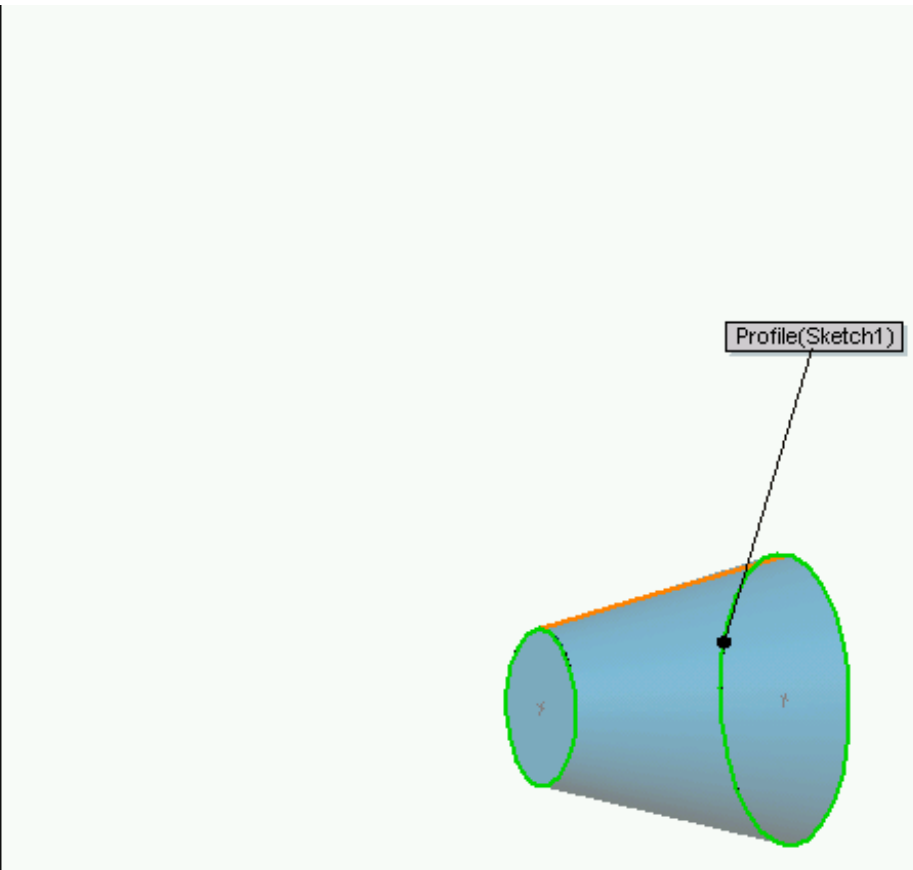
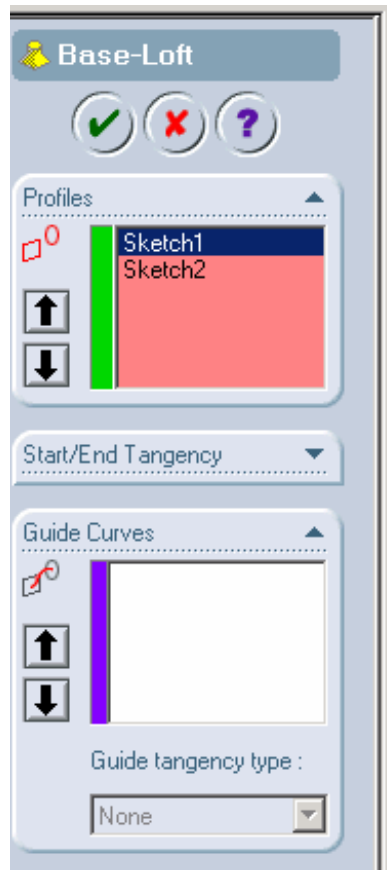

Primer 1

Nacrtati u aksonometrijskom izgledu mašinski deo prikazan na slici korišćenjem programskog paketa Solid Works 2001+.

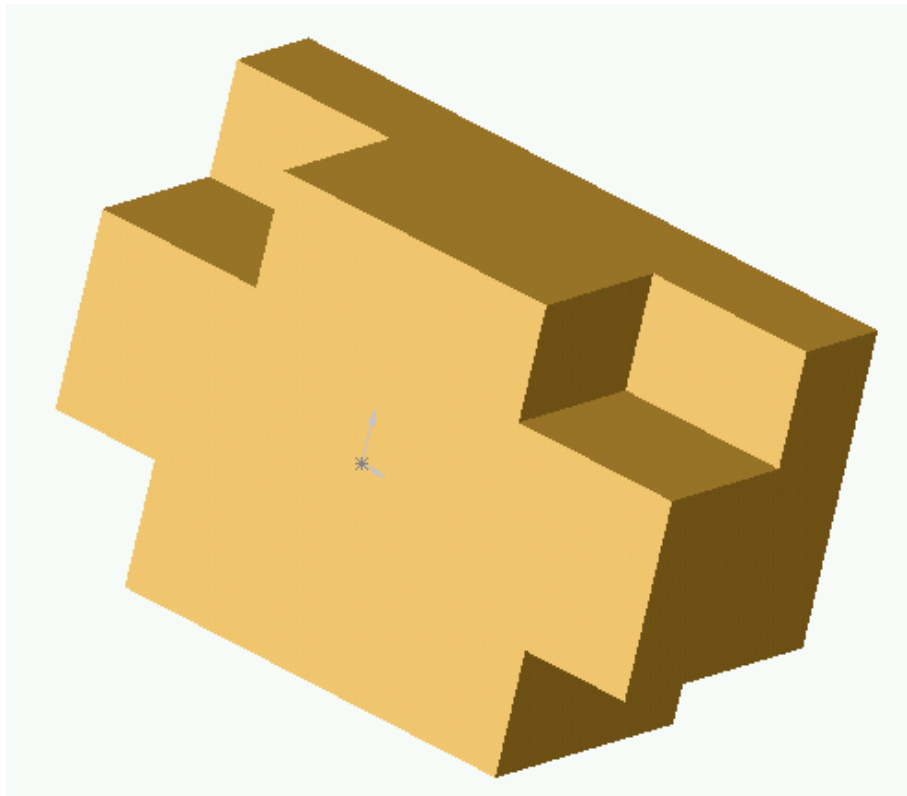

Animacija:



Primer 2

Nacrtati u aksonometrijskom izgledu mašinski deo prikazan na slici korišćenjem programskog paketa Solid Works 2001+.

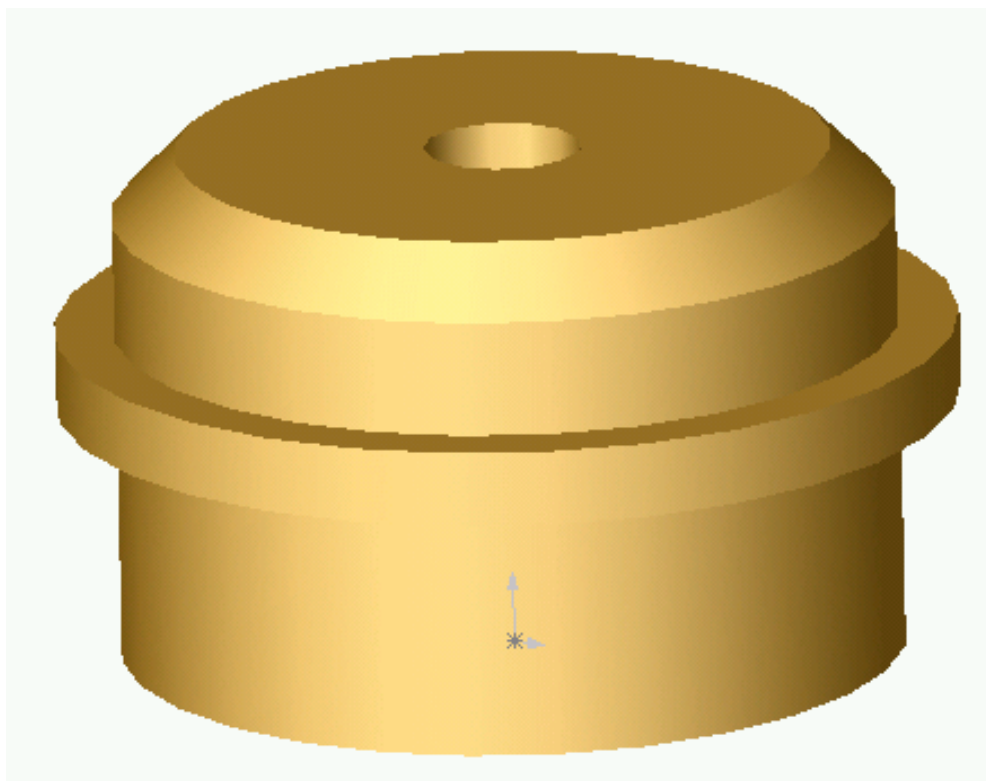

Animacija:



Primer 3

Nacrtati u aksonometrijskom izgledu mašinski deo prikazan na slici korišćenjem programskog paketa Solid Works 2001+.

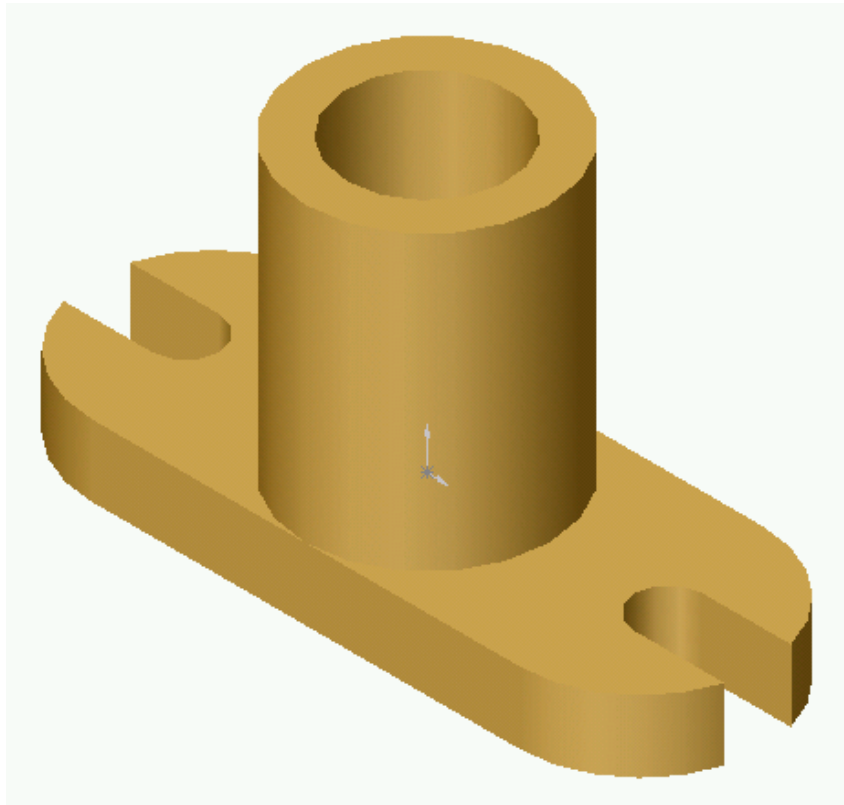

Animacija:



Primer 4

Nacrtati u aksonometrijskom izgledu mašinski deo prikazan na slici korišćenjem programskog paketa Solid Works 2001+.

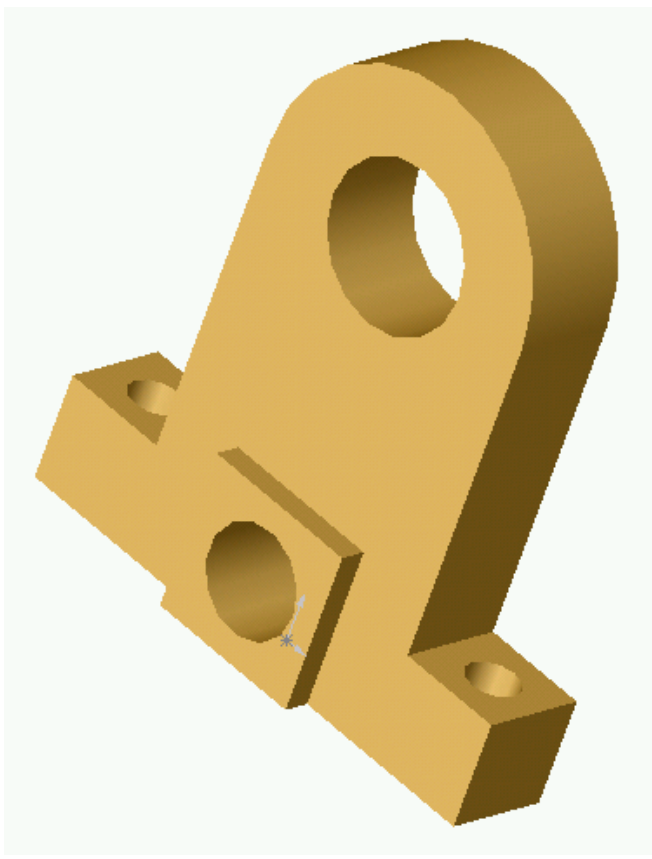

Animacija:



Primer 5

Nacrtati u aksonometrijskom izgledu mašinski deo prikazan na slici korišćenjem programskog paketa Solid Works 2001+.

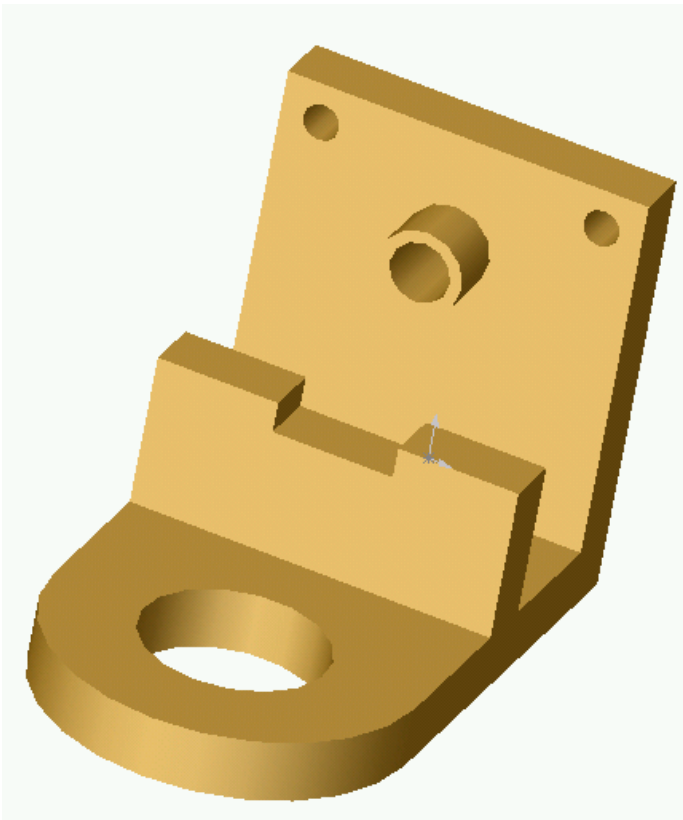

Animacija:



Primer 6

Nacrtati u aksonometrijskom izgledu mašinski deo prikazan na slici korišćenjem programskog paketa Solid Works 2001+.

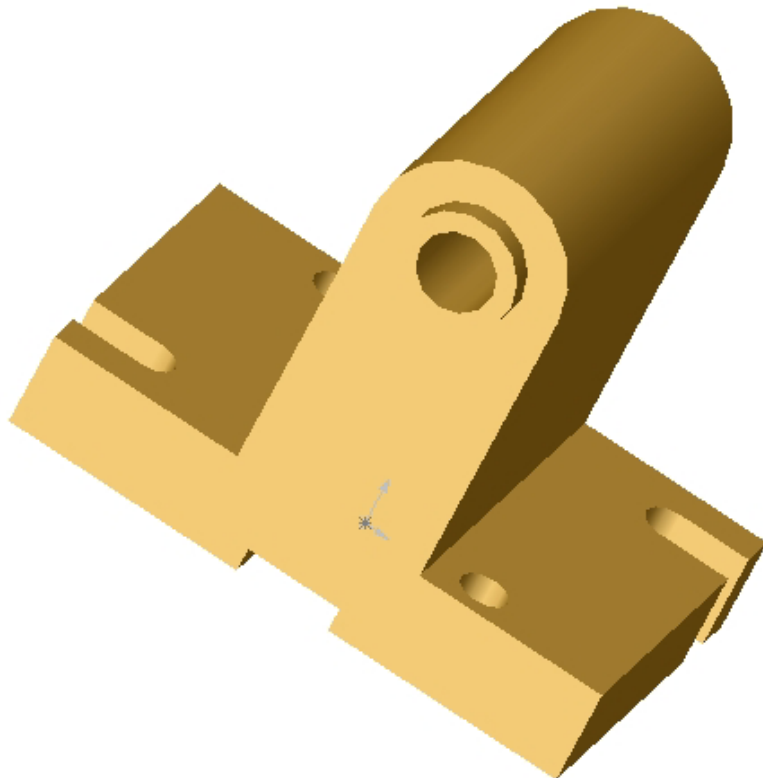

Animacija:

